



238 Pillow Street  
Butler, PA 16001  
724-283-4681  
724-283-5939 (fax)  
www.bwieagle.com

# PRODUCT INFORMATION BULLETIN

## AIR-EAGLE® GOLD DUAL CHANNEL REMOTE STOP SWITCH 900 MHz RF Transmitter MODEL 48-5100NS-24VDC

*New and Improved Performance!*

The Air-Eagle Gold Plus provides the same protection as the original Air-Eagle Gold but with enhanced output power. This allows for a 50% increase in overall range, while improving signal strength through and around buildings and other obstacles. These combine to maintain an even stronger "link" between transmitter and receiver.

### DESCRIPTION

The AIR-EAGLE GOLD PLUS RADIO REMOTE STOP SWITCH IS a machine mounted R.F. REMOTE STOP SWITCH designed to transmit a unique STOP signal to the AIR-EAGLE GOLD RECEIVER. The large center mounted STOP switch allows easy access by the operator. The unit includes a log-in/log-out button for system activation as well as a network switch for changing frequencies when communicating with multiple receivers. LED's provide a visual display of system status.

### CONTROLS & INDICATORS

**STOP ACTUATOR** - Latching pushbutton transmits a unique code continuously to the remote receiver until the operator resets the pushbutton.

**LOG-IN/LOG-OUT BUTTON** - A momentary pushbutton used to alert the system that the user is entering or leaving the hazardous location.

**STOP LED** - Red LED illuminates continuously when the STOP ACTUATOR depressed.

**CH1 LED** - When network is set to CH1, Green LED *blinks* briefly during the log-in and log-out procedures. This LED will illuminate *continuously* when the transmitter is linked to the CH1 receiver.

**CH2 LED** - When network is set to CH2, Green LED *blinks* briefly during the log-in and log-out procedures. This LED will illuminate *continuously* when the transmitter is linked to the CH2 receiver.

**NETWORK SWITCH** - Used to select which remote receiver you wish to communicate with.

### SYSTEM OPERATION

**User must select the appropriate network switch setting prior to logging in to the system...**

Once operator has reached the hazardous area, the LOG-IN button must be momentarily depressed to activate the system. If the system is properly linked, the green LED will be illuminated. If the operator pushes the STOP button, the stop signal is immediately sent to the receiver and the red STOP LED will illuminate. When the operator wishes to leave the area, prior to exceeding the range of the transmitter, he must push the LOG-OUT button to avoid having an unnecessary shut-down signal sent to the receiver.

Note - If the RF signal or DC power to the transmitter is lost, this will also initiate a stop condition at the remote receiver.



### DIMENSIONS

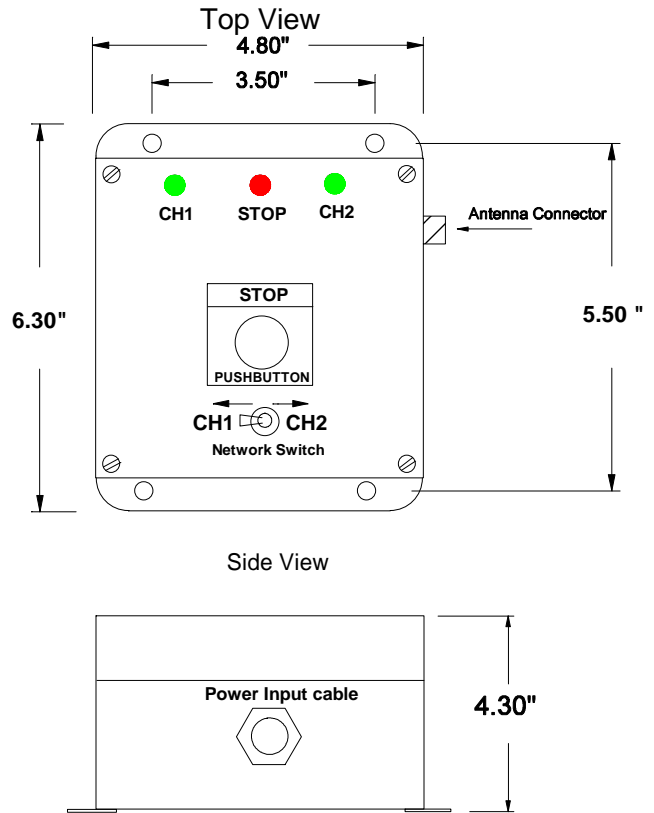

# AIR-EAGLE® GOLD PLUS

## DUAL CHANNEL REMOTE STOP SWITCH

### 900 MHz RF Transmitter

# MODEL 48-5100NS-24VDC

### INSTALLATION

1. Install external antenna on vehicle roof.
2. Locate the TNC Connector on the upper right side of the transmitter – Carefully thread the antenna’s coax plug onto the TNC connector.
3. A ten foot 2-conductor pigtail has been provided for DC power:  
(Black = -24VDC / White = +24VDC) Note! Be careful to observe polarity.
4. Make sure that the receiver (base) is powered up and properly installed prior to attempting to “Log-In”

### PC BOARD SET-UP INFORMATION

Note -This unit has been configured at the factory – the following information is for reference only.

DC INPUT TERMINAL STRIP (DC IN)	
Terminal 1	Positive (+) 24VDC INPUT
Terminal 2	Negative (-) 24VDC INPUT

INPUT 1 TERMINAL STRIP (INP1)	
Terminal 1	Log-in Switch Input (+)
Terminal 2	Log-in Switch Input (Common)
Terminal 3	Stop Switch Input (+)
Terminal 4	Stop Switch Input (Common)

I/O TERMINAL STRIP (TERM2)	
Not Used On This Model	

NETWORK SWITCH TERMINAL STRIP (NSW1)	
Terminal 1	Network Switch Input (+)
Terminal 2	Network Switch Input (Common)

NETWORK SWITCH CONFIGURATION OPTIONS (SEL1)		
SW #	OPEN	CLOSED
SW1	Network 1 / 2	Global Mode
SW2	Not Used	Not Used
SW3	Not Used	Not Used
SW4	Not Used	Not Used

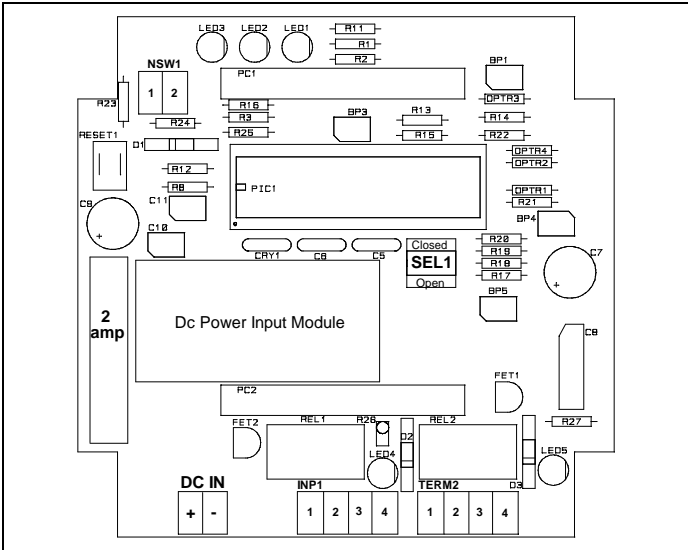

### SPECIFICATIONS

Power Supply	External 24VDC from mobile vehicle
Maximum Number of Transmitters	4 Transmitters to 1 Receiver
Transmit Frequency	900 MHz - 74 Channel Auto-Select
Transmit Range	Approximately 4500 feet

### LIMITED WARRANTY STATEMENT

BWI Eagle Inc. warrants the Air-Eagle Remote Control System, if properly used and installed, will be free from defects in material and workmanship for a period of 1 year after date of purchase. Said warranty to include the repair or replacement of defective equipment. This warranty does not cover damage due to external causes, including accident, problems with electrical power, usage not in accordance with product instructions, misuse, neglect, alteration, repair, improper installation, or improper testing. This limited warranty, and any implied warranties that may exist under state law, apply only to the original purchaser of the equipment, and last only for as long as such purchaser continues to own the equipment. This warranty replaces all other warranties, express or implied including, but not limited to, the implied warranties or merchantability and fitness for a particular purpose. BWI Eagle makes no express warranties beyond those stated here. BWI disclaims without limitation, implied warranties of merchantability and fitness for a particular purpose. Some jurisdictions do not allow the exclusion of implied warranties so this limitation may not apply to you. To obtain warranty service, contact BWI Eagle for a return material authorization. When returning equipment to BWI Eagle, the customer assumes the risk of damage or loss during shipping and is responsible for the shipping costs incurred.

DOCUMENT DATE: 23-Feb-05



238 Pillow Street  
Butler, PA 16001  
(724) 283-4681  
Fax (724) 283-5939  
[www.bwieagle.com](http://www.bwieagle.com)