



238 Pillow Street
Butler, PA 16001
724-283-4681
724-283-5939 (fax)
www.bwieagle.com

PRODUCT INFORMATION BULLETIN

AIR-EAGLE® GOLD PLUS REMOTE STOP SWITCH 900 MHz RF Transmitter MODEL 48-5100-24VDC

New and Improved Performance!

The Air-Eagle Gold Plus provides the same protection as the original Air-Eagle Gold but with enhanced output power. This allows for a 50% increase in overall range, while improving signal strength through and around buildings and other obstacles. These combine to maintain an even stronger "link" between transmitter and receiver.

DESCRIPTION

The AIR-EAGLE GOLD PLUS RADIO REMOTE STOP SWITCH is a machine mounted R.F. REMOTE STOP SWITCH designed to transmit a unique STOP signal to the AIR-EAGLE GOLD RECEIVER. The large center mounted STOP switch allows easy access by the operator. The unit includes a log-in/log-out button for system activation. Dual LED's provide a visual display of system status.

CONTROLS & INDICATORS

STOP ACTUATOR - Latching pushbutton transmits a unique code continuously to the remote receiver until the operator resets the pushbutton.

LOG-IN/LOG-OUT BUTTON - A momentary pushbutton used to alert the system that the user is entering or leaving the hazardous location.

STOP LED - Red LED illuminates continuously when the STOP ACTUATOR depressed.

CH1 LED - Green LED *blinks* briefly during the log-in and log-out procedures. This LED will illuminate *continuously* when the transmitter is linked to the receiver.

SYSTEM OPERATION

Once operator has reached the hazardous area, the LOG-IN button must be momentarily depressed to activate the system. If the system is properly linked, the green RX LED will be illuminated. If the operator pushes the STOP button, the stop signal is immediately sent to the receiver and the red STOP LED will illuminate. When the operator wishes to leave the area, prior to exceeding the range of the transmitter, he must push the LOG-OUT button to avoid having an unnecessary shut-down signal sent to the receiver.

Note – If the RF signal or DC power to the transmitter is lost, this will also initiate a stop condition at the remote receiver.



DIMENSIONS

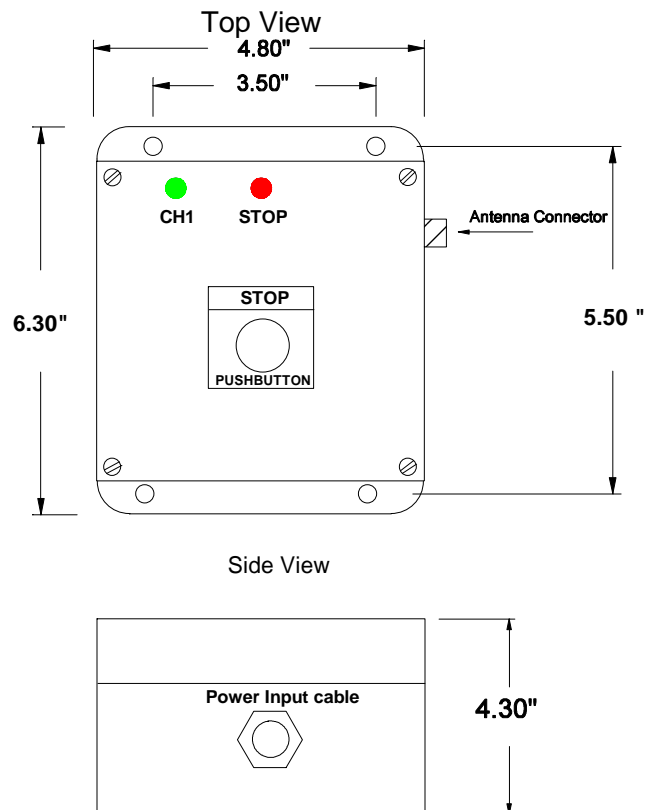

AIR-EAGLE® GOLD PLUS

REMOTE STOP SWITCH
900 MHz RF Transmitter

MODEL 48-5100-24VDC

INSTALLATION

1. Install external antenna on vehicle roof.
2. Locate the TNC Connector on the upper right side of the transmitter – Carefully thread the antenna's coax plug onto the TNC connector.
3. A ten foot 2-conductor pigtail has been provided for DC power:
(Black = -24VDC / White = +24VDC) Note! Be careful to observe polarity.
4. Make sure that the receiver (base) is powered up and properly installed prior to attempting to "Log-In"

PC BOARD SET-UP INFORMATION

Note -This unit has been configured at the factory – the following information is for reference only.

DC INPUT TERMINAL STRIP (DC IN)	
Terminal 1	Positive (+) 24VDC INPUT
Terminal 2	Negative (-) 24VDC INPUT

INPUT 1 TERMINAL STRIP (INP1)	
Terminal 1	Log-in Switch Input (+)
Terminal 2	Log-in Switch Input (Common)
Terminal 3	Stop Switch Input (+)
Terminal 4	Stop Switch Input (Common)

I/O TERMINAL STRIP (TERM2)	
Not Used On This Model	

NETWORK SWITCH TERMINAL STRIP (NSW1)	
Terminal 1	Network Switch Input (+)
Terminal 2	Network Switch Input (Common)

NETWORK SWITCH CONFIGURATION OPTIONS (SEL1)		
SW #	OPEN	CLOSED
SW1	Network 1/2	Global Mode
SW2	Not Used	Not Used
SW3	Not Used	Not Used
SW4	Not Used	Not Used

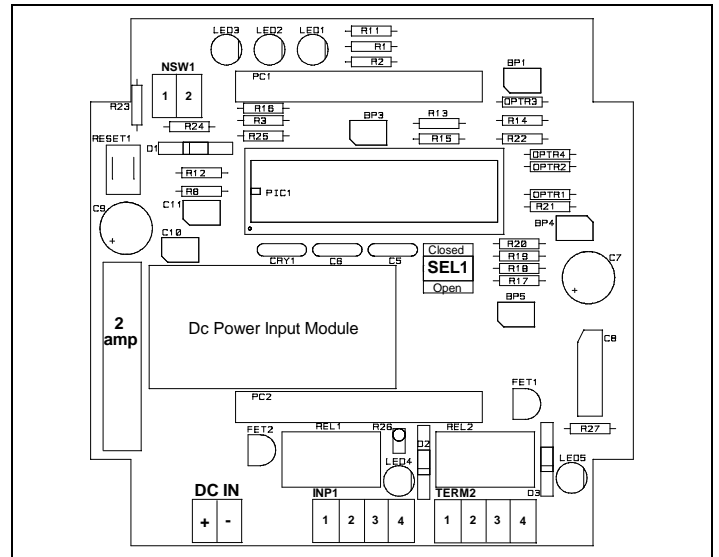

SPECIFICATIONS

Power Supply	External 24VDC from mobile vehicle
Maximum Number of Transmitters	4 Transmitters to 1 Receiver
Transmit Frequency	900 MHz - 74 Channel Auto-Select
Transmit Range	Approximately 4500 feet

LIMITED WARRANTY STATEMENT

BWI Eagle Inc. warrants the Air-Eagle Remote Control System, if properly used and installed, will be free from defects in material and workmanship for a period of **1 year** after date of purchase. Said warranty to include the repair or replacement of defective equipment. This warranty does not cover damage due to external causes, including accident, problems with electrical power, usage not in accordance with product instructions, misuse, neglect, alteration, repair, improper installation, or improper testing. This limited warranty, and any implied warranties that may exist under state law, apply only to the original purchaser of the equipment, and last only for as long as such purchaser continues to own the equipment. This warranty replaces all other warranties, express or implied including, but not limited to, the implied warranties of merchantability and fitness for a particular purpose. BWI Eagle makes no express warranties beyond those stated here. BWI disclaims without limitation, implied warranties of merchantability and fitness for a particular purpose. Some jurisdictions do not allow the exclusion of implied warranties so this limitation may not apply to you. To obtain warranty service, contact BWI Eagle for a return material authorization. When returning equipment to BWI Eagle, the customer assumes the risk of damage or loss during shipping and is responsible for the shipping costs incurred.

DOCUMENT DATE: 23-Feb-05



238 Pillow Street
Butler, PA 16001
(724) 283-4681
Fax (724) 283-5939
www.bwieagle.com