



238 Pillow Street
 Butler, PA 16001
 724-283-4681
 724-283-5939 (fax)
 www.bwieagle.com

PRODUCT INFORMATION BULLETIN

AIR-EAGLE® XLT 2.4GHz RF Transceiver DUAL CONTACT INPUT / OUTPUT MODEL 45-4000-HART

DESCRIPTION

The AIR-EAGLE XLT RF TRANSCEIVER is a dual I/O unit designed to transmit and receive unique signals from an identical unit located up to several miles away. This model comes equipped with dual contact inputs and dual relay outputs. This allows the user to not only transmit information out, but receive a confirming signal back that the operation was performed. A terminal strip has been provided for interfacing with external dry contact inputs as well as dry contact relay outputs. This unit can operate remote machinery such as pumps, gates, chutes etc.



PC BOARD SET-UP INFORMATION

Make the following connections on the PC Board Terminal Strip:

DC INPUT TERMINAL STRIP (DC IN)	
Terminal 1	Positive (+) 24VDC INPUT
Terminal 2	Negative (-) 24VDC INPUT

INPUT 1 TERMINAL STRIP (INP1)	
Terminal 1	CH1 Dry Contact Input (+)
Terminal 2	CH1 Dry Contact Input (Common)
Terminal 3	CH2 Dry Contact Input (Common)
Terminal 4	CH2 Dry Contact Input (+)

I/O TERMINAL STRIP (TERM2)	
Terminal 1	Relay 1 Common
Terminal 2	Relay 1 N/O
Terminal 3	Relay 2 Common
Terminal 4	Relay 2 N/O

NETWORK SWITCH CONFIGURATION OPTIONS (SEL1)			
SEL 1 (SW1 & 2):	Network Address	SW1	SW2
USED TO SET NETWORK FREQUENCY	#1	OPEN	OPEN
	#2	CLOSED	OPEN
	#3	OPEN	CLOSED
	#4	CLOSED	CLOSED

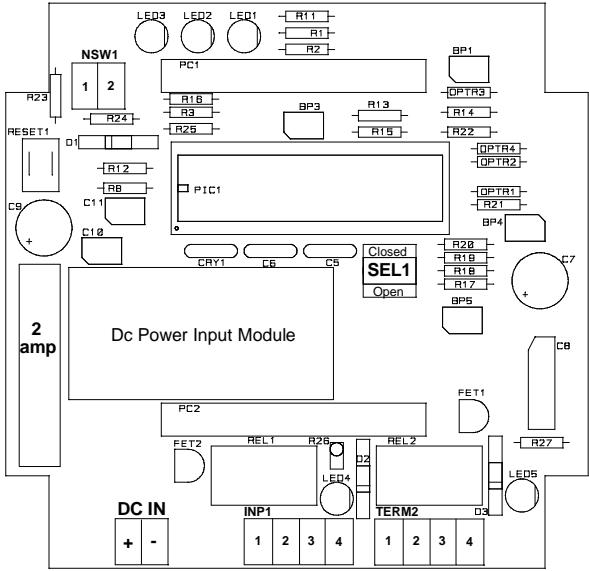

AIR-EAGLE® XLT

2.4GHz RF Transceiver

DUAL CONTACT INPUT / OUTPUT

MODEL 45-4000-HART

DIMENSIONS & INDICATORS

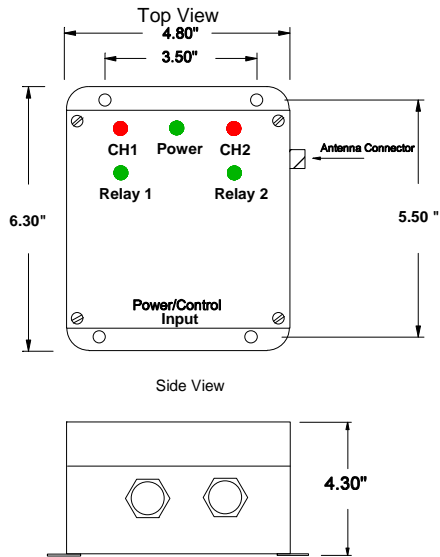

CH1 LED - Red LED illuminates continuously when the contact input for Channel 1 is closed.

POWER LED – Green LED illuminates continuously while power is applied to the transceiver.

CH2 LED - Red LED illuminates continuously when the contact input for Channel 2 is closed.

RELAY 1 LED - Green LED illuminates continuously while Relay #1 is energized.

RELAY 2 LED – Green LED illuminates continuously while Relay #2 is energized.

SPECIFICATIONS

Power Supply	24VDC (9 – 36 VDC)
Fuse Protected	2 amp
Transmit Frequency	2.4GHz Spread Spectrum
RF Output Power	50mW
Transmit Range	Up to 10 miles with external antenna - see accessories)
Operating Temperature	-40° to +85°
Enclosure	Fiberglass NEMA 12 + 13

REPLACEMENT PARTS & ACCESSORIES

PC Board (Main)	45-4002-HART
Optional Transceiver Antennas:	
2.4GHz Omni Directional Antenna Medium Range Operation – For Ranges Up to 2 miles *	49-3201
2.4GHz 13dB Yagi Antenna Long Range Operation – For Ranges Greater than 2 miles / Up to 10 miles *	49-3202
Inline Lightning Arrestor	49-5002
* = Line of Sight	

LIMITED WARRANTY STATEMENT

BWI Eagle Inc. warrants the Air-Eagle Remote Control System, if properly used and installed, will be free from defects in material and workmanship for a period of **1 year** after date of purchase. Said warranty to include the repair or replacement of defective equipment. This warranty does not cover damage due to external causes, including accident, problems with electrical power, usage not in accordance with product instructions, misuse, neglect, alteration, repair, improper installation, or improper testing. This limited warranty, and any implied warranties that may exist under state law, apply only to the original purchaser of the equipment, and last only for as long as such purchaser continues to own the equipment. This warranty replaces all other warranties, express or implied including, but not limited to, the implied warranties or merchantability and fitness for a particular purpose. BWI Eagle makes no express warranties beyond those stated here. BWI disclaims without limitation, implied warranties of merchantability and fitness for a particular purpose. Some jurisdictions do not allow the exclusion of implied warranties so this limitation may not apply to you. To obtain warranty service, contact BWI Eagle for a return material authorization. When returning equipment to BWI Eagle, the customer assumes the risk of damage or loss during shipping and is responsible for the shipping costs incurred.

DOCUMENT DATE: 19-Jul-04



238 Pillow Street
 Butler, PA 16001
 (724) 283-4681
 Fax (724) 283-5939
www.bwieagle.com