



238 Pillow Street
Butler, PA 16001
724-283-4681
724-283-5939 (fax)
www.bwieagle.com

PRODUCT INFORMATION BULLETIN

AIR-EAGLE[®] XLT 900MHz RF Transceiver DUAL CONTACT INPUT / OUTPUT MODEL 44-4050-120VAC

DESCRIPTION

The AIR-EAGLE XLT RF TRANSCEIVER is a dual I/O unit designed to transmit and receive unique signals from an identical unit located up to several miles away. This model comes equipped with dual contact inputs and dual relay outputs. This allows the user to not only transmit information out, but receive a confirming signal back that the operation was performed. A terminal strip has been provided for interfacing with external dry contact inputs as well as dry contact relay outputs. This unit can operate remote machinery such as pumps, gates, chutes etc.

PC BOARD SET-UP INFORMATION

Make the following connections on the PC Board Terminal Strip:

DC INPUT TERMINAL STRIP (DC IN)	
Terminal 1	Positive (+) 12VDC INPUT from 120VAC adapter
Terminal 2	Negative (-) 12VDC INPUT from 120VAC adapter

INPUT 1 TERMINAL STRIP (INP1)	
Terminal 1	CH1 Dry Contact Input (+)
Terminal 2	CH1 Dry Contact Input (Common)
Terminal 3	CH2 Dry Contact Input (Common)
Terminal 4	CH2 Dry Contact Input (+)

I/O TERMINAL STRIP (TERM2)	
Terminal 1	Relay 1 Common
Terminal 2	Relay 1 N/O
Terminal 3	Relay 2 Common
Terminal 4	Relay 2 N/O

NETWORK SWITCH CONFIGURATION OPTIONS (SEL1)			
SEL 1 (SW1 & 2):	Network Address	SW1	SW2
USED TO SET NETWORK FREQUENCY	#1	OPEN	OPEN
	#2	CLOSED	OPEN
	#3	OPEN	CLOSED
	#4	CLOSED	CLOSED

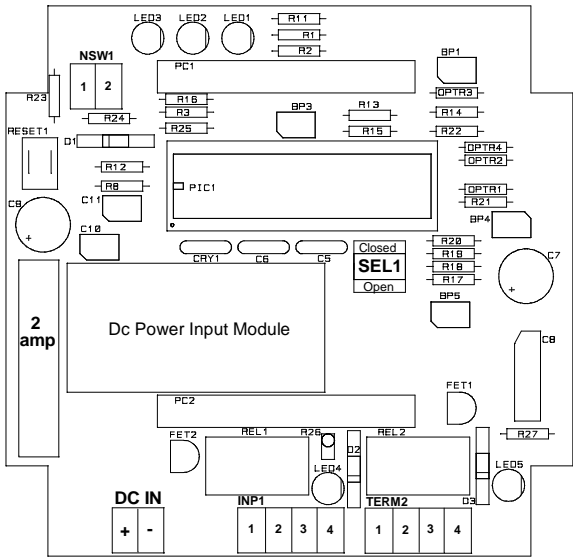

APPROVALS

United States (FCC)	OUR-9XSTREAM
Canada (IC)	4214A-9XSTREAM

AIR-EAGLE® XLT

900MHz RF Transceiver

DUAL CONTACT INPUT / OUTPUT

MODEL 44-4050 -120VAC

DIMENSIONS & INDICATORS

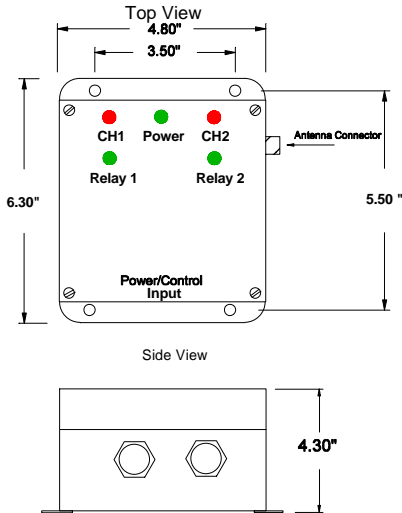

- CH1 LED** - Red LED illuminates continuously when the contact input for Channel 1 is closed.
- POWER LED** - Green LED illuminates continuously while power is applied to the transceiver.
- CH2 LED** - Red LED illuminates continuously when the contact input for Channel 2 is closed.
- RELAY 1 LED** - Green LED illuminates continuously while Relay #1 is energized.
- RELAY 2 LED** - Green LED illuminates continuously while Relay #2 is energized.

RELAY OPERATION

44-4050 Signals Received	44-1300 Signals Received	Relay Function
Input 1 Closed	Button 1	Relay 1 energizes, latching
Input 2 Closed	Button 2	Relay 1 de-energizes
N/A	Button 3	Not used on this model
N/A	Button 4	Relay 2 energizes, latching
N/A	Button 5	Relay 2 de-energizes
N/A	Button 6	Not used on this model
N/A	Button 7	Not used on this model
N/A	Button 8	Not used on this model
N/A	Button 9	Programming button only – see product information on 44-1300

SPECIFICATIONS

Power Supply	120VAC from wall adapter
Fuse Protected	2 amp
Transmit Frequency	900MHz Spread Spectrum
RF Output Power	140mW
Transmit Range	Up to 10 miles with external antenna - see accessories)
Operating Temperature	-40° to +85°
Enclosure	Fiberglass NEMA 4, 4x, 12 + 13

REPLACEMENT PARTS & ACCESSORIES

PC Board (Main)	44-4052
Optional Transceiver Antennas:	
900MHz Omni Directional Antenna Medium Range Operation – For Ranges Up to 2 miles *	49-3101
900MHz 13dB Yagi Antenna Long Range Operation – For Ranges Greater than 2 miles / Up to 10 miles *	49-3102
Inline Lightening Arrestor	49-5002
* = Line of Sight	

LIMITED WARRANTY STATEMENT

BWI Eagle Inc. warrants the Air-Eagle Remote Control System, if properly used and installed, will be free from defects in material and workmanship for a period of **1 year** after date of purchase. Said warranty to include the repair or replacement of defective equipment. This warranty does not cover damage due to external causes, including accident, problems with electrical power, usage not in accordance with product instructions, misuse, neglect, alteration, repair, improper installation, or improper testing. This limited warranty, and any implied warranties that may exist under state law, apply only to the original purchaser of the equipment, and last only for as long as such purchaser continues to own the equipment. This warranty replaces all other warranties, express or implied including, but not limited to, the implied warranties or merchantability and fitness for a particular purpose. BWI Eagle makes no express warranties beyond those stated here. BWI disclaims without limitation, implied warranties of merchantability and fitness for a particular purpose. Some jurisdictions do not allow the exclusion of implied warranties so this limitation may not apply to you. To obtain warranty service, contact BWI Eagle for a return material authorization. When returning equipment to BWI Eagle, the customer assumes the risk of damage or loss during shipping and is responsible for the shipping costs incurred.

DOCUMENT DATE: 5-Jan-05



238 Pillow Street
Butler, PA 16001
(724) 283-4681
Fax (724) 283-5939
www.bwieagle.com