



238 Pillow Street
Butler, PA 16001
724-283-4681
724-283-5939 (fax)
www.bwieagle.com

PRODUCT INFORMATION BULLETIN

AIR-EAGLE® XLT 900 MHz RF Transmitter DUAL CONTACT INPUT MODEL 44-1000-24VDC

DESCRIPTION

The model 44-1000, AIR-EAGLE XLT TX is a dual contact input R.F. transmitter designed to transmit unique signals to any AIR-EAGLE XLT RECEIVER which can be located up to 1 mile (*) away. This model comes equipped with a terminal strip for ease of interfacing with any external **dry contact input** devices such as tilt switches, flow switches, speed switches etc.

(*) – Longer distances can be obtained with external antennas

PC BOARD SET-UP INFORMATION

Make the following connections on the PC Board Terminal Strip:

DC INPUT TERMINAL STRIP (DC IN)	
Terminal 1	Positive (+) 24VDC INPUT
Terminal 2	Negative (-) 24VDC INPUT

INPUT 1 TERMINAL STRIP (INP1)	
Terminal 1	CH1 Dry Contact Input (+)
Terminal 2	CH1 Dry Contact Input (Common)
Terminal 3	CH2 Dry Contact Input (Common)
Terminal 4	CH2 Dry Contact Input (+)

I/O TERMINAL STRIP (TERM2)	
Terminal 1	Not Used On This Model
Terminal 2	Not Used On This Model
Terminal 3	Not Used On This Model
Terminal 4	Not Used On This Model

NETWORK SWITCH TERMINAL STRIP (NSW1)	
Terminal 1	Not Used On This Model
Terminal 2	Not Used On This Model

NETWORK SWITCH CONFIGURATION OPTIONS (SEL1)			
SEL 1 (SW1 & 2):	Network Address	SW1	SW2
USED TO SET NETWORK FREQUENCY	#1	OPEN	OPEN
	#2	CLOSED	OPEN
	#3	OPEN	CLOSED
	#4	CLOSED	CLOSED

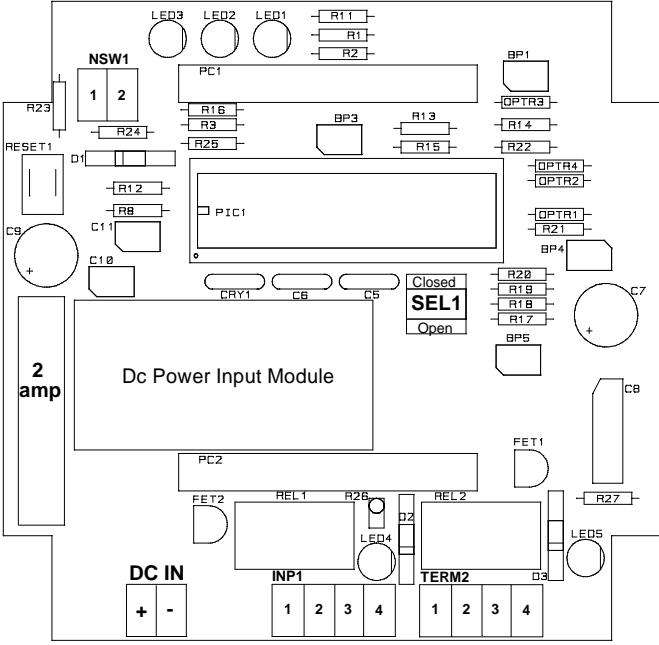

AIR-EAGLE® XLT

900 MHz RF Transmitter
DUAL CONTACT INPUT

MODEL 44-1000-24VDC

DIMENSIONS & INDICATORS

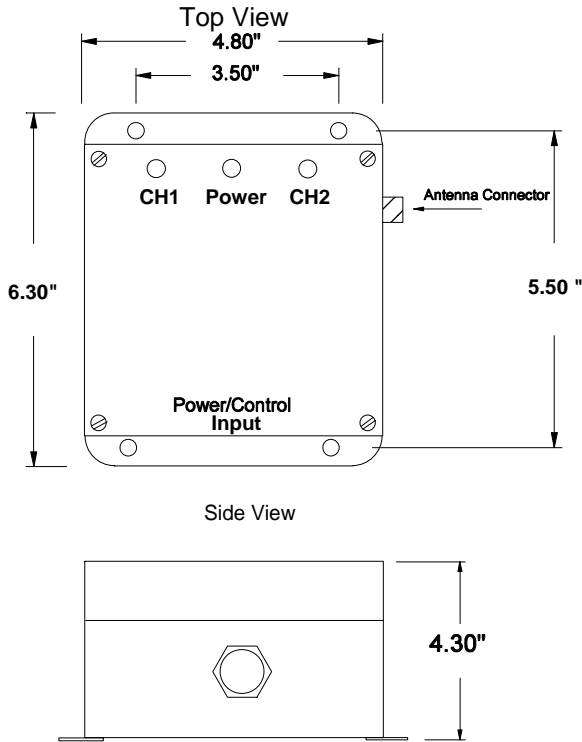

CH1 LED – Red LED illuminates continuously when the contact input for Channel 1 is closed.

POWER LED – Green LED illuminates continuously while power is applied to the transmitter.

CH2 LED - Red LED illuminates continuously when the contact input for Channel 2 is closed.

SPECIFICATIONS

Power Supply	18 – 36 VDC Input
Fuse Protected	2 amp
Transmit Frequency	900MHz Spread Spectrum
RF Output Power	140mW
Transmit Range	Up to 10 miles with external antenna - see accessories)
Enclosure	Fiberglass NEMA 12 + 13

REPLACEMENT PARTS & ACCESSORIES

PC Board (Main)	44-1002-24VDC
Air-Eagle XLT Receiver	44-2000
Replacement /Optional Antennas:	
900MHz Portable Antenna	49-1103
900MHz Omni Directional Base Antenna (For Distances Of Up To 10 Miles *)	49-3101
* = Line of Sight	

LIMITED WARRANTY STATEMENT

BWI Eagle Inc. warrants the Air-Eagle Remote Control System, if properly used and installed, will be free from defects in material and workmanship for a period of **1 year** after date of purchase. Said warranty to include the repair or replacement of defective equipment. This warranty does not cover damage due to external causes, including accident, problems with electrical power, usage not in accordance with product instructions, misuse, neglect, alteration, repair, improper installation, or improper testing. This limited warranty, and any implied warranties that may exist under state law, apply only to the original purchaser of the equipment, and last only for as long as such purchaser continues to own the equipment. This warranty replaces all other warranties, express or implied including, but not limited to, the implied warranties or merchantability and fitness for a particular purpose. BWI Eagle makes no express warranties beyond those stated here. BWI disclaims without limitation, implied warranties of merchantability and fitness for a particular purpose. Some jurisdictions do not allow the exclusion of implied warranties so this limitation may not apply to you. To obtain warranty service, contact BWI Eagle for a return material authorization. When returning equipment to BWI Eagle, the customer assumes the risk of damage or loss during shipping and is responsible for the shipping costs incurred.

DOCUMENT DATE: 28-Apr-04



238 Pillow Street
Butler, PA 16001
(724) 283-4681
Fax (724) 283-5939
www.bwieagle.com