



238 Pillow Street
 Butler, PA 16001
 724-283-4681
 724-283-5939 (fax)
 www.bwieagle.com

PRODUCT INFORMATION BULLETIN

AIR-EAGLE® FM2 900MHz RF Receiver DUAL RELAY OUTPUT **MODEL 43-5050N4W-120VAC**

DESCRIPTION

The AIR-EAGLE FM2 RF RECEIVER is a dual relay output unit designed to receive unique signals from an AIR-EAGLE FM2 HANDHELD TRANSMITTER located up to 1200 feet away. Enclosed in a rugged NEMA 4 enclosure, this unit is well-suited to meet the environmental challenges of any industry. This unit can operate remote machinery such as pumps, gates, chutes, conveyors etc.



PC BOARD SET-UP INFORMATION

Make the following connections on the PC Board Terminal Strip:

DC INPUT TERMINAL STRIP (DC IN)	
Terminal 1	Positive (+) 12VDC INPUT from internal 120VAC
Terminal 2	Negative (-) 12VDC INPUT from internal 120VAC

INPUT 1 TERMINAL STRIP (INP1)	
Terminal 1	N/A
Terminal 2	N/A
Terminal 3	N/A
Terminal 4	N/A

I/O TERMINAL STRIP (TERM2)	
Terminal 1	Relay 1 Common
Terminal 2	Relay 1 N/O
Terminal 3	Relay 2 Common
Terminal 4	Relay 2 N/O

NETWORK SWITCH CONFIGURATION OPTIONS (SEL1)			
SEL 1 (SW1 & 2):	Network Address	SW1	SW2
<i>USED TO SET NETWORK FREQUENCY</i>	#1	OPEN	OPEN
	#2	CLOSED	OPEN
	#3	OPEN	CLOSED
	#4	CLOSED	CLOSED

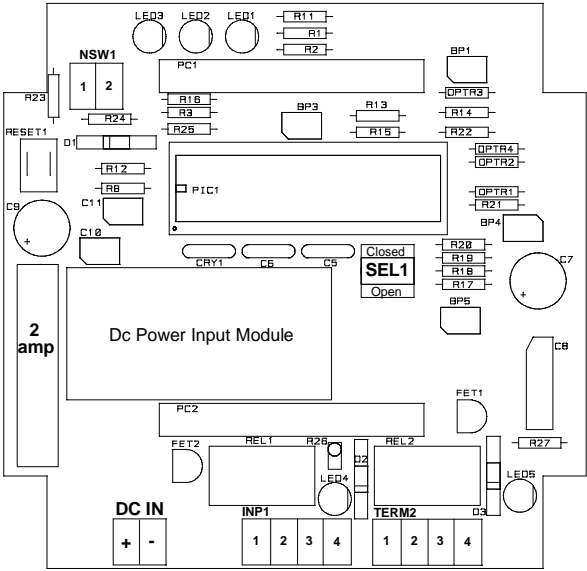

AIR-EAGLE® FM2

900MHz RF Receiver
DUAL RELAY OUTPUT

MODEL 43-5050N4W-120VAC

DIMENSIONS & INDICATORS

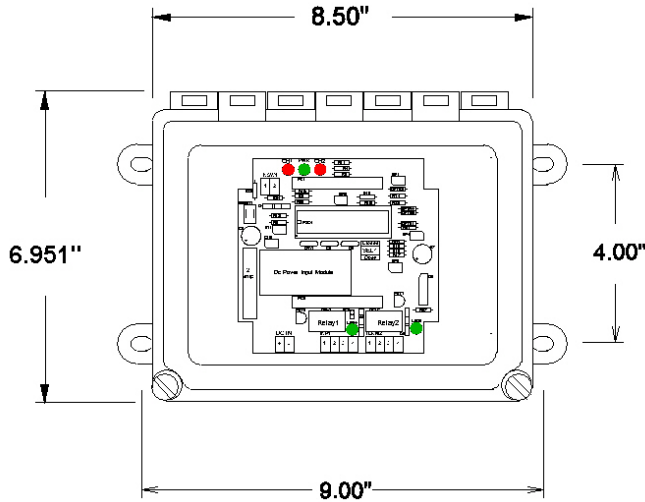

CH1 LED – Not used on this model.

POWER LED – Green LED illuminates continuously while power is applied to the transceiver.

CH2 LED – Not used on this model.

RELAY 1 LED - Green LED illuminates continuously while Relay #1 is energized.

RELAY 2 LED – Green LED illuminates continuously while Relay #2 is energized.

RELAY OPERATION

43-1300 Signals Received	Relay Function
Button 1	Relay 1 energizes, latching
Button 2	Relay 1 de-energizes
Button 3	Not used on this model
Button 4	Relay 2 energizes, latching
Button 5	Relay 2 de-energizes
Button 6	Not used on this model
Button 7	Not used on this model
Button 8	Not used on this model
Button 9	Programming button only – see product information on 43-1300

SPECIFICATIONS

Power Supply	120VAC from internal adapter
Fuse Protected	2 amp
Relay Contacts	SPST N/O 5 amps @ 120VAC
Receiver Range	Up to 1200 feet with external antenna – (see accessories)
Receiver Frequency	900MHz Spread Spectrum
RF Channels	Four independent network frequencies
Enclosure	Hinged fiberglass with window / NEMA 3, 3R, 4, 12, 13
Operating Temp	-40° F - +185° F

REPLACEMENT PARTS & ACCESSORIES

PC Board (Main)	43-5052N4W
Standard Antenna (Included):	
900MHz TNC Portable Antenna (For distances up to 600 feet*)	49-1103
Optional Antenna & Accessories:	
900MHz Omni Directional Base Antenna (For distances up to 1200 feet*)	49-3101
Flex Coax Cable w/Connectors	49-4000-XX (XX = # of Feet)
Inline Lightning Arrestor	49-5002
* = Line of Sight	

LIMITED WARRANTY STATEMENT

BWI Eagle Inc. warrants the Air-Eagle Remote Control System, if properly used and installed, will be free from defects in material and workmanship for a period of **1 year** after date of purchase. Said warranty to include the repair or replacement of defective equipment. This warranty does not cover damage due to external causes, including accident, problems with electrical power, usage not in accordance with product instructions, misuse, neglect, alteration, repair, improper installation, or improper testing. This limited warranty, and any implied warranties that may exist under state law, apply only to the original purchaser of the equipment, and last only for as long as such purchaser continues to own the equipment. This warranty replaces all other warranties, express or implied including, but not limited to, the implied warranties or merchantability and fitness for a particular purpose. BWI Eagle makes no express warranties beyond those stated here. BWI disclaims without limitation, implied warranties of merchantability and fitness for a particular purpose. Some jurisdictions do not allow the exclusion of implied warranties so this limitation may not apply to you. To obtain warranty service, contact BWI Eagle for a return material authorization. When returning equipment to BWI Eagle, the customer assumes the risk of damage or loss during shipping and is responsible for the shipping costs incurred.

DOCUMENT DATE: 20-Oct-05



238 Pillow Street
Butler, PA 16001
(724) 283-4681
Fax (724) 283-5939
www.bwieagle.com