



238 Pillow Street  
Butler, PA 16001  
724-283-4681  
724-283-5939 (fax)  
www.bwieagle.com

# PRODUCT INFORMATION BULLETIN

## AIR-EAGLE® FM2 900MHz RF Transceiver DUAL CONTACT INPUT / OUTPUT MODEL 43-4100-120VAC

### DESCRIPTION

The AIR-EAGLE FM2 RF TRANSCEIVER IS a dual I/O unit designed to transmit and receive unique signals from an identical unit located up to 1200 feet away. This model comes equipped with dual contact inputs and dual relay outputs. This allows the user to not only transmit information out, but receive a confirming signal back that the operation was performed. A terminal strip has been provided for interfacing with external dry contact inputs as well as dry contact relay outputs. This unit can operate remote machinery such as pumps, gates, chutes etc.



### PC BOARD SET-UP INFORMATION

Make the following connections on the PC Board Terminal Strip:

DC INPUT TERMINAL STRIP (DC IN)	
Terminal 1	Positive (+) 12VDC INPUT from 120VAC adapter
Terminal 2	Negative (-) 12VDC INPUT from 120VAC adapter

INPUT 1 TERMINAL STRIP (INP1)	
Terminal 1	CH1 Dry Contact Input (+)
Terminal 2	CH1 Dry Contact Input (Common)
Terminal 3	CH2 Dry Contact Input (Common)
Terminal 4	CH2 Dry Contact Input (+)

I/O TERMINAL STRIP (TERM2)	
Terminal 1	Relay 1 Common
Terminal 2	Relay 1 N/O
Terminal 3	Relay 2 Common
Terminal 4	Relay 2 N/C

NETWORK SWITCH CONFIGURATION OPTIONS (SEL1)			
SEL 1 (SW1 & 2):	Network Address	SW1	SW2
USED TO SET NETWORK FREQUENCY	#1	OPEN	OPEN
	#2	CLOSED	OPEN
	#3	OPEN	CLOSED
	#4	CLOSED	CLOSED

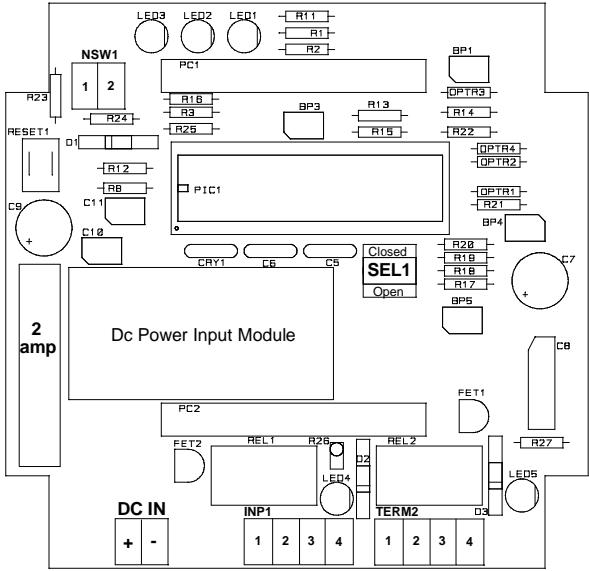

# AIR-EAGLE® FM2

## 900MHz RF Transceiver

### DUAL CONTACT INPUT / OUTPUT

## MODEL 43-4100-120VAC

### DIMENSIONS & INDICATORS

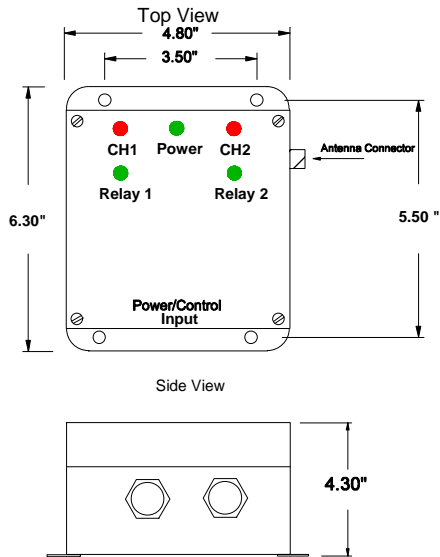

**CH1 LED** - Red LED illuminates continuously when the contact input for Channel 1 is closed.

**POWER LED** - Green LED illuminates continuously while power is applied to the transceiver.

**CH2 LED** - Red LED illuminates continuously when the contact input for Channel 2 is closed.

**RELAY 1 LED** - Green LED illuminates continuously while Relay #1 is energized.

**RELAY 2 LED** - Green LED illuminates continuously while Relay #2 is energized.

### SPECIFICATIONS

Power Supply	120VAC from wall adapter
Fuse Protected	2 amp
Transceiver Frequency	900MHz Spread Spectrum
RF Channels	Four independent network frequencies
RF Output Power	4mW
Transceiver Range	Up to 1200 feet with external antenna - see accessories)
Transmitter Data	Two DRY Contact Inputs
Relay Contacts	SPST N/O 5 amps @ 120VAC
Enclosure	ABS Plastic, NEMA 3, 3R, 4, 4X, 12, 13
Operating Temp	-40° F - +185° F

### REPLACEMENT PARTS & ACCESSORIES

PC Board (Main)	43-4102
Standard Antenna (Included):	
900MHz TNC Portable Antenna (For distances up to 600 feet*)	49-1103
Optional Antenna & Accessories:	
900MHz Omni Directional Base Antenna (For distances up to 1200 feet*)	49-3101
Flex Coax Cable w/Connectors	49-4000-XX (XX = # of Feet)
Inline Lightning Arrestor	49-5002
* = Line of Sight	

### LIMITED WARRANTY STATEMENT

BWI Eagle Inc. warrants the Air-Eagle Remote Control System, if properly used and installed, will be free from defects in material and workmanship for a period of **1 year** after date of purchase. Said warranty to include the repair or replacement of defective equipment. This warranty does not cover damage due to external causes, including accident, problems with electrical power, usage not in accordance with product instructions, misuse, neglect, alteration, repair, improper installation, or improper testing. This limited warranty, and any implied warranties that may exist under state law, apply only to the original purchaser of the equipment, and last only for as long as such purchaser continues to own the equipment. This warranty replaces all other warranties, express or implied including, but not limited to, the implied warranties or merchantability and fitness for a particular purpose. BWI Eagle makes no express warranties beyond those stated here. BWI disclaims without limitation, implied warranties of merchantability and fitness for a particular purpose. Some jurisdictions do not allow the exclusion of implied warranties so this limitation may not apply to you. To obtain warranty service, contact BWI Eagle for a return material authorization. When returning equipment to BWI Eagle, the customer assumes the risk of damage or loss during shipping and is responsible for the shipping costs incurred.

DOCUMENT DATE: 7-Feb-05



238 Pillow Street  
Butler, PA 16001  
(724) 283-4681  
Fax (724) 283-5939  
[www.bwieagle.com](http://www.bwieagle.com)