



238 Pillow Street
Butler, PA 16001
724-283-4681
724-283-5939 (fax)
www.bwieagle.com

PRODUCT INFORMATION BULLETIN

AIR-EAGLE® FM2 900 MHz RF Transmitter BATTERY POWERED REMOTE STOP SWITCH MODEL 43-1100

DESCRIPTION

The AIR-EAGLE FM2 REMOTE STOP SWITCH is a machine or equipment mountable R.F. REMOTE STOP SWITCH designed to transmit a unique STOP signal to the AIR-EAGLE FM2 RECEIVER. The large center mounted STOP switch allows easy access by the operator. The internal lithium batteries allow the transmitter to be operated in areas without a power source.



PC BOARD SET-UP INFORMATION

Make the following connections on the PC Board Terminal Strip:

DC INPUT TERMINAL STRIP (DC IN)	
Terminal 1	Positive (+) 12VDC from internal lithium batteries
Terminal 2	Negative (-) 12VDC from internal lithium batteries

INPUT 1 TERMINAL STRIP (INP1)	
Terminal 1	Stop Switch Input
Terminal 2	Stop Switch Input
Terminal 3	N/A
Terminal 4	N/A

I/O TERMINAL STRIP (TERM2)	
Terminal 1	Not Used On This Model
Terminal 2	Not Used On This Model
Terminal 3	Not Used On This Model
Terminal 4	Not Used On This Model

NETWORK SWITCH TERMINAL STRIP (NSW1)	
Terminal 1	Not Used On This Model
Terminal 2	Not Used On This Model

NETWORK SWITCH CONFIGURATION OPTIONS (SEL1)			
SEL 1 (SW1 & 2):	Network Address	SW1	SW2
USED TO SET NETWORK FREQUENCY	#1	OPEN	OPEN
	#2	CLOSED	OPEN
	#3	OPEN	CLOSED
	#4	CLOSED	CLOSED

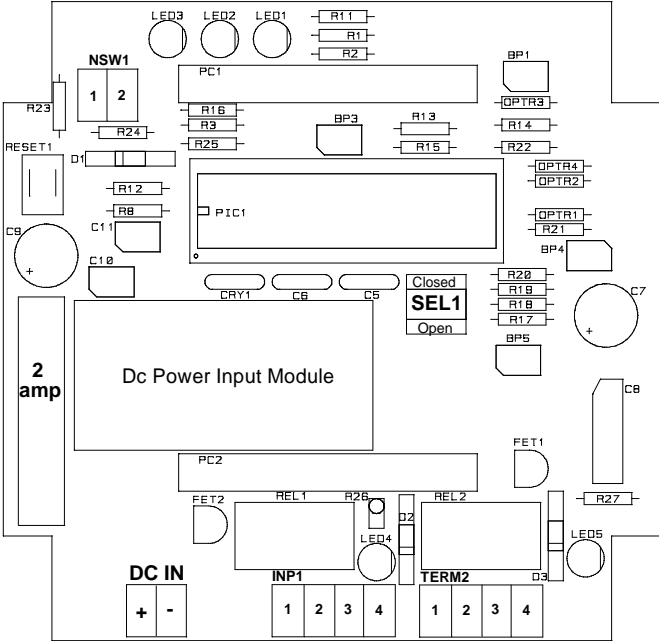

AIR-EAGLE® FM2

900 MHz RF Transmitter

BATTERY POWERED

REMOTE STOP SWITCH

43-1100

DIMENSIONS & INDICATORS

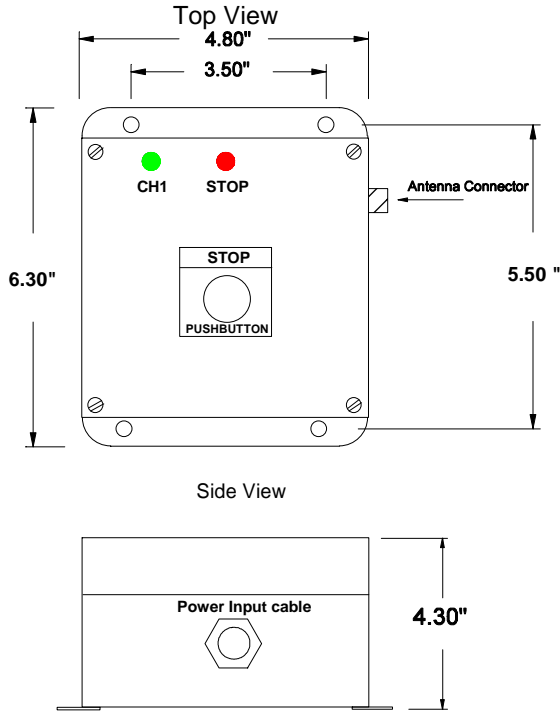

CH1 LED – Red LED illuminates continuously when the contact input for Channel 1 is closed.

POWER LED – Green LED illuminates continuously while power is applied to the transmitter.

SPECIFICATIONS

Power Supply	14 VDC from internal batteries
Fuse Protected	2 amp
Transmitter Data	DRY Contact Inputs – Pre-wired to STOP pushbutton
Transmit Frequency	900MHz Spread Spectrum
RF Channels	Four independent network frequencies
RF Output Power	4mW
Transmit Range	Up to 1200 feet with external antenna - see accessories)
Enclosure	ABS Plastic, NEMA 3, 3R, 4, 4X, 12, 13
Operating Temp	-40° F - +185° F

REPLACEMENT PARTS & ACCESSORIES

PC Board (Main)	43-1102
Lithium Batteries (4 ea required per TX)	TADIRAN 3.6V TL5903
Standard Antenna (Included):	
900MHz TNC Portable Antenna (For distances up to 600 feet*)	49-1103
Optional Antenna & Accessories:	
900MHz Omni Directional Base Antenna (For distances up to 1200 feet*)	49-3101
Flex Coax Cable w/Connectors	49-4000-XX (XX = # of Feet)
Inline Lightning Arrestor	49-5002
* = Line of Sight	

LIMITED WARRANTY STATEMENT

BWI Eagle Inc. warrants the Air-Eagle Remote Control System, if properly used and installed, will be free from defects in material and workmanship for a period of **1 year** after date of purchase. Said warranty to include the repair or replacement of defective equipment. This warranty does not cover damage due to external causes, including accident, problems with electrical power, usage not in accordance with product instructions, misuse, neglect, alteration, repair, improper installation, or improper testing. This limited warranty, and any implied warranties that may exist under state law, apply only to the original purchaser of the equipment, and last only for as long as such purchaser continues to own the equipment. This warranty replaces all other warranties, express or implied including, but not limited to, the implied warranties or merchantability and fitness for a particular purpose. BWI Eagle makes no express warranties beyond those stated here. BWI disclaims without limitation, implied warranties of merchantability and fitness for a particular purpose. Some jurisdictions do not allow the exclusion of implied warranties so this limitation may not apply to you. To obtain warranty service, contact BWI Eagle for a return material authorization. When returning equipment to BWI Eagle, the customer assumes the risk of damage or loss during shipping and is responsible for the shipping costs incurred.

DOCUMENT DATE: 3-Mar-05



238 Pillow Street
Butler, PA 16001
(724) 283-4681
Fax (724) 283-5939
www.bwieagle.com