



238 Pillow Street
Butler, PA 16001
724-283-4681
724-283-5939 (fax)
www.bwieagle.com

PRODUCT INFORMATION BULLETIN

TAC-MONITOR Proportional Speed Monitor MODEL 22-8100-4500A

DESCRIPTION

BWI Eagle's highly accurate PROPORTIONAL SPEED MONITOR converts rotary shaft speed (RPM) into analog 4-20mA output. This allows "true-slip" monitoring during the critical ramp-up period of conveyors. The TAC-MONITOR interfaces directly with the customer's PLCs. Remote sensors may be located up to 2 miles from the modular control unit.

INSTALLATION

Disconnect AC power before proceeding with installation

1. Mount the TAC-MONITOR socket inside an existing control panel or other suitable protective enclosure
2. Make the following connections on the socket:

TERMINAL	CONNECTION
1	Sensor - Common (-)
2	Sensor - Positive (+)
3 - 4	No Connection
5 - 6	120 VAC
7	No Connection
8	4-20mA Output - Common (-)
9	4-20mA Output - Positive (+)
10 - 11 - 12	No Connection

3. Install EAGLE PROXIMITY SENSOR at roller or shaft. See sensor installation section.

LED INDICATORS

1. **SENSOR LED** - Pulses at the rate of speed being received by the sensor
2. **POWER LED** - Indicates that power is applied to unit
3. **LINE OPEN** - When illuminated, indicates the 4-20mA output line is open or the line resistance is greater than 500 ohm.

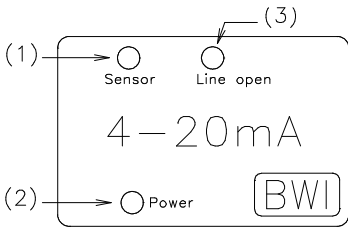

SPECIFICATIONS

AC Input	120 VAC 10 W	
Fuse Protected	1 amp	
Input Frequency Range	.166hz – 75.00 Hertz	
Output	Proportional 4-20mA D.C.	
Linearity	Better than 1%	*See Note
Accuracy	Better than 1%	
Repeatability	Better than .5%	
Enclosure	ABS Plastic	

**Note – For maximum accuracy, please allow 10 to 15 minute warm-up period after initial 120VAC is applied.*

REPLACEMENT AND OPTIONAL PARTS

DESCRIPTION	PART NUMBER
Control Module	22-8102-4500A
Mounting Socket	22-8003
Threaded PVC Proximity Sensor	10-7139
I.S. Threaded PVC Prox Sensor	10-7039
I.S. Zener Barrier	10-7072

TAC-MONITOR

Proportional Speed Monitor

MODEL 22-8100-4500A

APPLICATION INFORMATION

MODEL 22-8100-4500A

This model has an INPUT FREQUENCY RANGE of .166hz to 75.00hz. By installing 1 (one) target on the roller or shaft, the following formula can be used to convert to RPM's:

INPUT FREQUENCY * 60 = RPM

Examples:

$.166\text{hz} * 60 = 10 \text{ RPM}$
$37.58\text{hz} * 60 = 2254.80 \text{ RPM}$
$75.00\text{hz} * 60 = 4500 \text{ RPM}$

This model has a factory set span of 74.834hz (75.00hz - .166hz). Multiplying 74.834hz * 60 will give the span in RPM's.

$74.834\text{hz} * 60 = 4490.04 \text{ RPM}$

Dividing 4490.04 / 160 will give the RPM resolution for each .1mA increment.

$4490.04 / 160 = 28.06 \text{ RPM per .1mA output}$

By adding additional targets to the roller or shaft, a lower RPM range can be obtained. The following examples will show how to calculate the speed range for 4 (four) targets.

$\text{INPUT FREQUENCY} * 60 / 4 \text{ TARGETS} = \text{ACTUAL RPM}$

Examples:

$.166\text{hz} * 60 / 4 = 2.49 \text{ RPM}$
$37.58\text{hz} * 60 / 4 = 563.70 \text{ RPM}$
$75.00\text{hz} * 60 / 4 = 1125.00 \text{ RPM}$

CONCLUSION: By changing the number of targets on the roller or shaft, different speed ranges can be obtained from the same model.

Examples:

1 Target = 10 RPM to 4500 RPM
2 Targets = 5 RPM to 2250 RPM
4 Targets = 2.50 RPM to 1125 RPM

DIMENSIONS

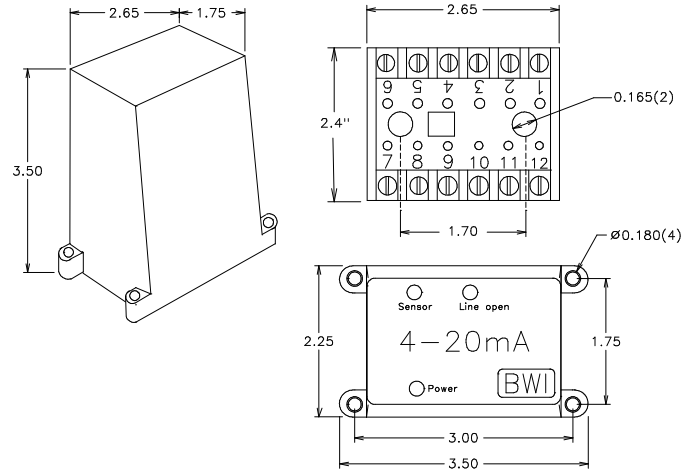

DOCUMENT DATE: 2-May-02



238 Pillow Street
Butler, PA 16001
(724) 283-4681
Fax (724) 283-5939
www.bwieagle.com