



238 Pillow Street  
Butler, PA 16001  
724-283-4681  
724-283-5939 (fax)  
www.bwieagle.com

# PRODUCT INFORMATION BULLETIN

## TAC-MONITOR Proportional Speed Monitor MODEL 22-8100-160A

### DESCRIPTION

BWI Eagle's highly accurate PROPORTIONAL SPEED MONITOR converts rotary shaft speed (RPM) into analog 4-20mA output. This allows "true-slip" monitoring during the critical ramp-up period of conveyors. The TAC-MONITOR interfaces directly with the customer's PLCs. Remote sensors may be located up to 2 miles from the modular control unit.

### INSTALLATION

Disconnect AC power before proceeding with installation

1. Mount the TAC-MONITOR socket inside an existing control panel or other suitable protective enclosure
2. Make the following connections on the socket:

TERMINAL	CONNECTION
1	Sensor - Common (-)
2	Sensor - Positive (+)
3 - 4	No Connection
5 - 6	120 VAC
7	No Connection
8	4-20mA Output - Common (-)
9	4-20mA Output - Positive (+)
10 - 11 - 12	No Connection

3. Install EAGLE PROXIMITY SENSOR at roller or shaft. See sensor installation section.

### LED INDICATORS

1. **SENSOR LED** - Pulses at the rate of speed being received by the sensor
2. **POWER LED** - Indicates that power is applied to unit
3. **LINE OPEN** - When illuminated, indicates the 4-20mA output line is open or the line resistance is greater than 500 ohm.

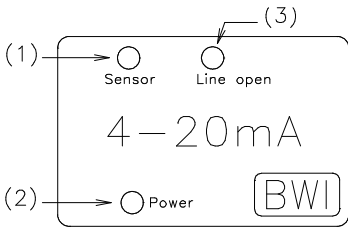

### SPECIFICATIONS

AC Input	120 VAC 10 W	
Fuse Protected	1 amp	
Input Frequency Range	.166hz - 2.66 Hertz	
Output	Proportional 4-20mA D.C.	
Linearity	Better than 1%	<b>*See Note</b>
Accuracy	Better than 1%	
Repeatability	Better than .5%	
Enclosure	ABS Plastic	

**\*Note – For maximum accuracy, please allow 10 to 15 minute warm-up period after initial 120VAC is applied.**

### REPLACEMENT AND OPTIONAL PARTS

DESCRIPTION	PART NUMBER
Control Module	22-8102-160A
Mounting Socket	22-8003
Threaded PVC Proximity Sensor	10-7139
I.S. Threaded PVC Prox Sensor	10-7039
I.S. Zener Barrier	10-7072

# TAC-MONITOR

## Proportional Speed Monitor

### MODEL 22-8100-160A

#### APPLICATION INFORMATION

#### MODEL 22-8100-160A

This model has an INPUT FREQUENCY RANGE of .166hz to 2.66hz. By installing 1 (one) target on the roller or shaft, the following formula can be used to convert to RPM's:

$$\text{INPUT FREQUENCY} * 60 = \text{RPM}$$

*Examples:*

$.166\text{hz} * 60 = 9.96 \text{ RPM}$
$1.33\text{hz} * 60 = 79.80 \text{ RPM}$
$2.66\text{hz} * 60 = 160.00 \text{ RPM}$

This model has a factory set span of 2.494hz (2.66hz - .166hz). Multiplying 2.494hz \* 60 will give the span in RPM's.

$$2.494\text{hz} * 60 = 149.64 \text{ RPM}$$

Dividing 149.64 / 160 will give the RPM resolution for each .1mA increment.

$$149.64 / 160 = .935 \text{ RPM per .1mA output}$$

By adding additional targets to the roller or shaft, a lower RPM range can be obtained. The following examples will show how to calculate the speed range for 4 (four) targets.

$$\text{INPUT FREQUENCY} * 60 / 4 \text{ TARGETS} = \text{ACTUAL RPM}$$

*Examples:*

$.166\text{hz} * 60 / 4 = 2.49 \text{ RPM}$
$1.41\text{hz} * 60 / 4 = 21.15 \text{ RPM}$
$2.66\text{hz} * 60 / 4 = 39.90 \text{ RPM}$

CONCLUSION: By changing the number of targets on the roller or shaft, different speed ranges can be obtained from the same model.

*Examples:*

1 Target = 9.96 RPM to 160.00 RPM
2 Targets = 4.98 RPM to 80.00 RPM
4 Targets = 1.77 RPM to 40.00 RPM

#### DIMENSIONS

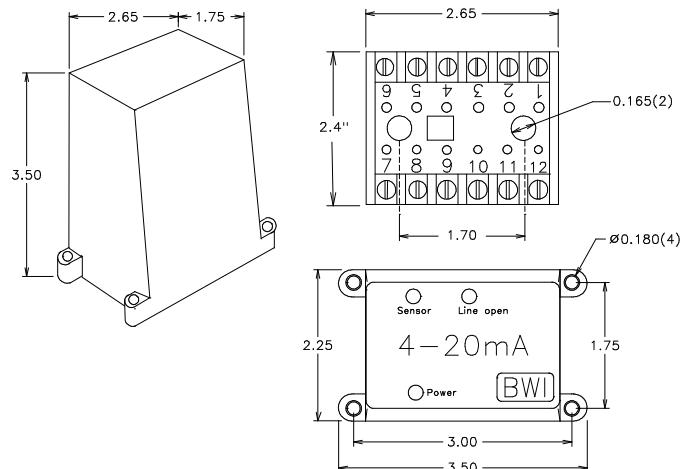

DOCUMENT DATE: 17-Apr-02



238 Pillow Street  
Butler, PA 16001  
(724) 283-4681  
Fax (724) 283-5939  
[www.bwieagle.com](http://www.bwieagle.com)