



238 Pillow Street
Butler, PA 16001
724-283-4681
724-283-5939 (fax)
www.bwieagle.com

PRODUCT INFORMATION BULLETIN

TAC-SWITCH Critical Speed Switch MODEL 22-8000ALS-P SERIES

BOTE APPROVAL

1207-90

DESCRIPTION

The EAGLE TAC SWITCH 22-8000ALS-P Models are a series of low speed switches that monitor speed and detect motion to as slow as 1 RPM in all types of machinery and apparatus. The "P" series provides a pulse output to drive an external counter. The EAGLE TAC SWITCH utilizes a non-contacting proximity sensor that may be remotely located up to two miles from the control area. Enclosed in durable ABS plastic, the socket mounted control unit conveniently mounts inside an existing electrical panel or O.E.M control box. Ideal for conveyors, crushers, fans, motors and other rotating machinery applications.

INSTALLATION

Disconnect AC power before proceeding with installation

1. Mount the TAC-SWITCH socket inside an existing control panel or other suitable protective enclosure
2. Make the following connections on the socket:

TERMINAL	CONNECTION
1	Sensor - Common (-)
2	Sensor - Positive (+)
3*	Pulse Output (+)
4	Pulse Output (-)
5 - 6	120 VAC
7	Relay - N/C (1)
8	Relay - Common (1)
9	Relay - N/O (1)
10	Relay - N/C (2)
11	Relay - Common (2)
12	Relay - N/O (2)

Note: Terminal #3 from Tac-Switch must be wired to Terminal #1 on external counter module

Terminal #4 from Tac-Switch must be wired to Terminal #2 on external counter module.

3. Install EAGLE PROXIMITY SENSOR at roller or shaft. See sensor installation section.



CONTROLS AND INDICATORS

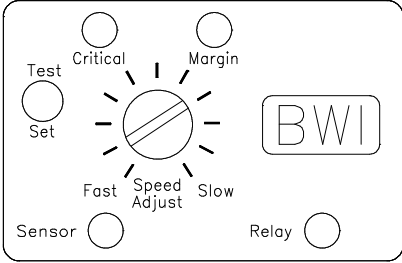

SET UP AND TESTING

Final calibration should be performed with the belt loaded and running at normal speed.

1. Turn SPEED control CCW until it stops (approximately 7 o'clock)
2. Hold switch in set position to energize relay.
3. Turn SPEED control CW slowly until CRITICAL SPEED LED stays on continuously.
4. Continue turning SPEED control until MARGIN LED stays on continuously.
5. Turn SPEED control CCW until MARGIN LED begins to blink at the same rate as SENSOR PULSE LED. The CRITICAL SPEED LED must stay on continuously.
6. After RELAY STATUS LED is illuminated, return switch to RUN position (center)
7. A momentary TEST position is provided to simulate the loss of sensor signal which releases the control relay

TAC-SWITCH

Critical Speed Switch

MODEL 22-8000ALS-P SERIES

SPECIFICATIONS

AC Input	120VAC 8W
Fuse Protected	1 amp
Speed Ranges	
ALS-1P	1 - 30 RPM
ALS-6P	6 - 60 RPM
ALS-15P	15 - 100 RPM
ALS-25P	25 - 200 RPM
Relay Contacts	DPDT 5 amp @ 120VAC
Safety Delay	1 Second
Response Time	1 Second or Less
Enclosure	ABS Plastic

DIMENSIONS

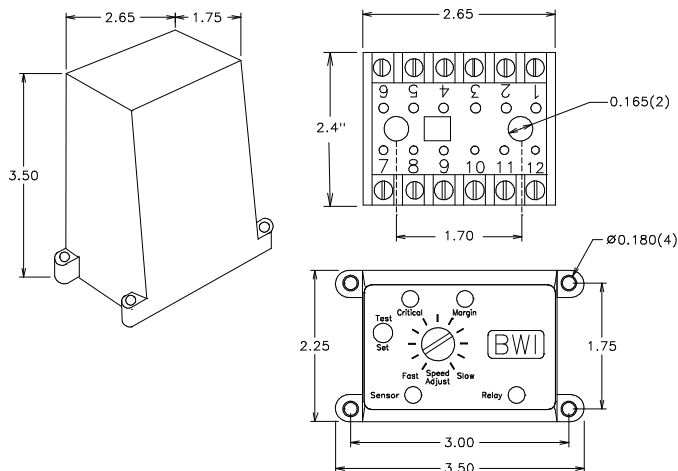

REPLACEMENT AND OPTIONAL PARTS

Control Module	22-8002ALS-1P,6P,15P, OR 25P
External Pulse Counter Module	99-COU-0001
Mounting Socket	22-8003
Threaded PVC Proximity Sensor	10-7139
I.S. Threaded PVC Proximity Sensor	10-7039
I.S. Zener Barrier	10-7072

TYPICAL BELT STARTER

TYPICAL BELT STARTER
22-8000 INSTALLATION

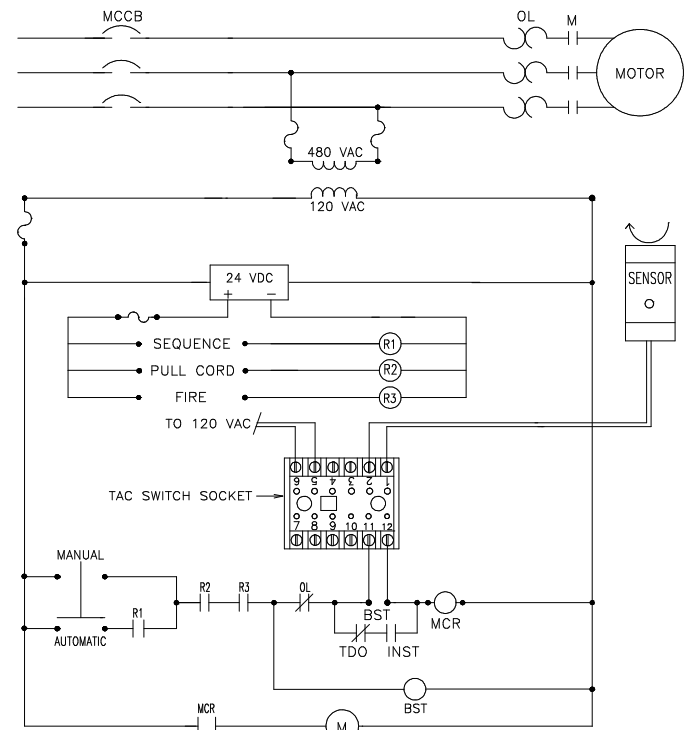

FIGURE 1

DOCUMENT DATE: 2-May-02



238 Pillow Street
Butler, PA 16001
(724) 283-4681
Fax (724) 283-5939
www.bwieagle.com